

Roof Framing Jobsite Reference Pack

A simplified printable guide built from your source pages. It is meant to help a DIYer or apprentice orient themselves before working, sketching, or talking to a code official, engineer, or experienced builder.

Important use note

This pack is educational, not a stamped plan. Local code, snow, wind, seismic, load path, species/grade, and span tables still control final decisions.

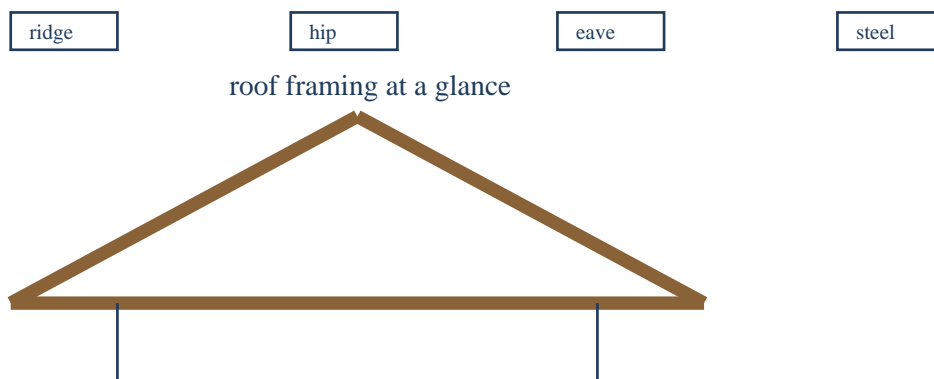

What this pack covers

- Basic roof anatomy: rafters, ridge boards, ties, joists, bearing lines, and sheathing.
- Common roof forms: gable, hip, gambrel, flat or low-slope, dormers, and parapet edges.
- Special systems: post-and-beam, plank-and-beam, and light-gauge steel framing.
- Quick jobsite reminders and plain-English rules distilled from the source pages.

Suggested use: print double-sided, keep it in a binder, and write your own local span tables, uplift notes, and flashing details in the margins.

1. Roof-framing big picture

A roof frame has to do four jobs at once: carry gravity loads, resist uplift and racking, hold a stable shape, and create a dry ventilated assembly above the building.

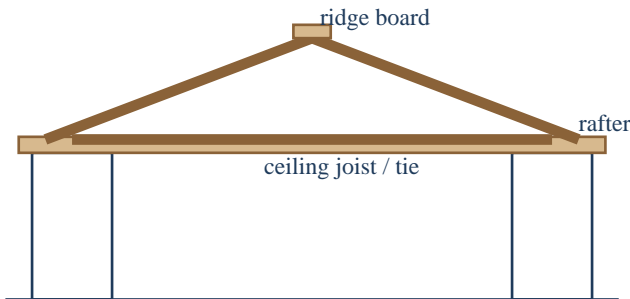

simple rafter triangle

What to remember	Common field mistakes
<ul style="list-style-type: none">• Rafters or roof joists carry roof loads to walls, beams, or posts.• The ridge board is an alignment member in a typical steep rafter roof; it is not automatically a beam.• Ties, joists, and proper bearing keep the roof from spreading.• Sheathing turns many individual members into one diaphragm.	<ul style="list-style-type: none">• Treating the ridge board like a structural ridge beam without design.• Forgetting the roof load path continues down into walls and foundations.• Thinking the roof finish layer alone provides structural stiffness.• Skipping uplift hardware where wind exposure or code requires it.

Field note

A good roof is not just a shape. It is a load path tied from roof surface to wall line to foundation.

2. Common roof forms

Your source pages show several roof families. The framing method changes with shape, but the logic stays the same: define bearing lines, keep spans realistic, and control how special members meet at hips, valleys, and ridges.

Common roof forms

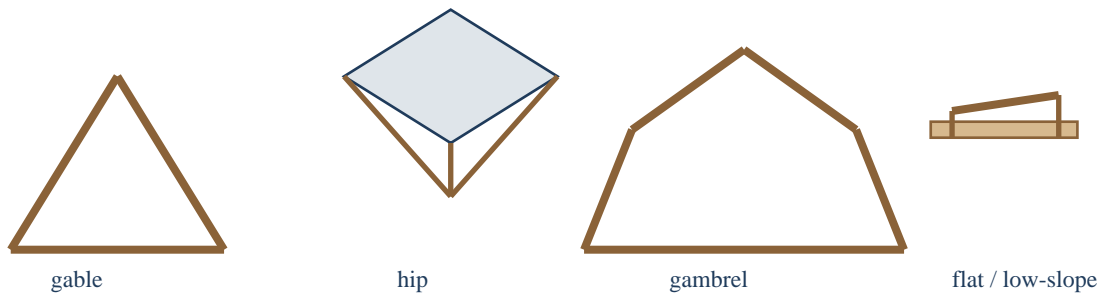

Form notes	When complexity rises
<ul style="list-style-type: none"> • Gable roofs are usually the simplest starting point for light-frame work. • Hip roofs add hip rafters and many shorter jack rafters. • Gambrel roofs create a break in slope and often need extra layout care. • Flat or low-slope roofs are framed more like floor joists and still need drainage. 	<ul style="list-style-type: none"> • Valleys collect water and framing congestion. • Irregular shapes increase flashing and cut-list errors. • Every change in slope or opening usually adds headers or trimmers. • Simple plans usually build faster and leak less.

Field note

Every extra valley, dormer, or roof break looks small on paper and large on site.

3. Wood rafters, spans, and bearing

The wood-rafter pages emphasize that dimension lumber rafters are a core subsystem of light-frame construction. Member size, spacing, species, grade, and load all matter; the quick ranges on source pages are orientation only, not final design values.

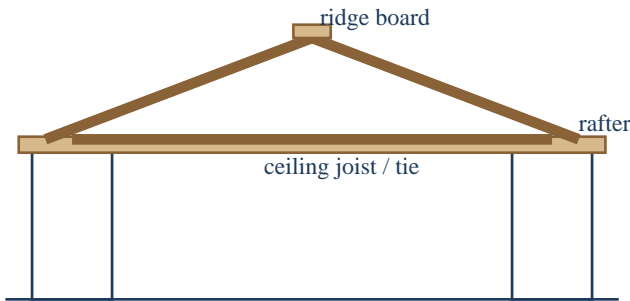

simple rafter triangle

Span-thinking approach	Quick reminders
<ul style="list-style-type: none"> • Use span tables for the real answer; do not size rafters by guesswork alone. • Spacing is often 12, 16, or 24 inches on center depending on load and sheathing. • Low-slope members under 3:12 behave differently and may need beam design at the ridge line. • Leave room for insulation depth and roof ventilation where required. 	<ul style="list-style-type: none"> • More snow load or wider spacing usually pushes member size up. • Deep members may be needed for both strength and insulation thickness. • Check bearing length at supports and cut seats cleanly. • Do not oversimplify the difference between a ridge board and a ridge beam.

Field note

People often ask, "What size rafter do I need?" The real question is span + spacing + load + species + slope + support condition.

4. Ridge boards, ties, and uplift resistance

The ridge pages show two critical ideas: the ridge board keeps opposing rafters aligned, and ties help keep the roof from spreading apart or lifting under wind action. Connection details matter as much as member size.

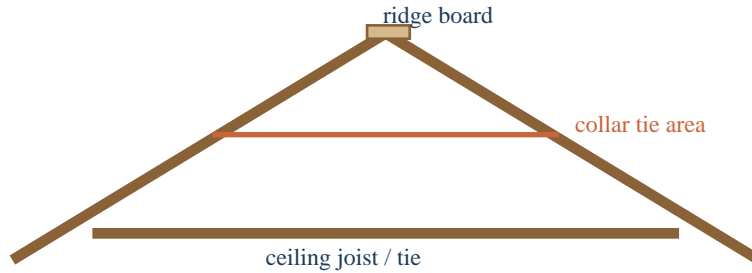

Key concepts	Bad assumptions
<ul style="list-style-type: none">• A ridge board should be at least as deep as the plumb cuts at the upper ends of the rafters.• Rafters framed opposite each other should meet cleanly and be fastened correctly.• Collar ties and ceiling-joist ties do different jobs; do not mix the terms casually.• Metal anchors or straps may be required to resist uplift.	<ul style="list-style-type: none">• Assuming toenails alone solve all uplift problems.• Using ties in the wrong location and expecting the same behavior.• Leaving the ridge line wavy because layout drifted during assembly.• Treating a connector callout like a decorative option.

Field note

The roof usually fails at its weakest connection before it fails in the middle of a member.

5. Eave support and the birdsmouth cut

One of the most practical details in your source set is the eave support condition. The seat cut lets the rafter bear on the top plate or beam, but every cut also removes wood, so it has to be deliberate.

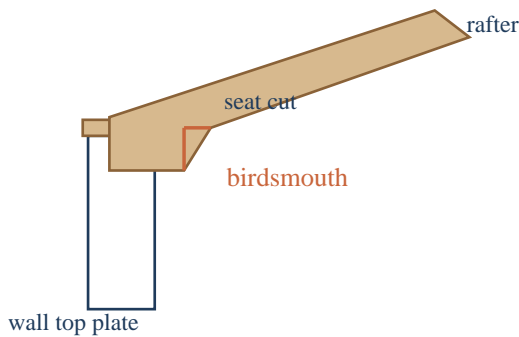

Safe-thinking approach	Common mistakes
<ul style="list-style-type: none"> • Use a clean birdsmouth so the rafter bears fully instead of rocking on a point. • Keep enough wood above the notch so the rafter retains its critical depth. • Check overhang length, fascia line, and soffit strategy before cutting a full batch. • Where rafters frame into a wall, coordinate blocking and any attic floor or ceiling joists. 	<ul style="list-style-type: none"> • Cutting too deep at the birdsmouth and weakening the rafter. • Letting each rafter tail drift so the fascia line snakes. • Forgetting that wall thickness and plate buildup affect seat geometry. • Installing members first and planning ventilation later.

Field note

A bad birdsmouth is a small cut that creates a large headache.

6. Eaves, rakes, soffits, and ventilation

Roof edges are not just trim. They are where structure, drainage, air movement, and appearance all collide. Your source pages show exposed tails, wide vented soffits, narrow soffits, and rake details.

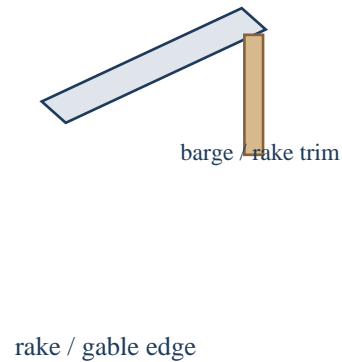
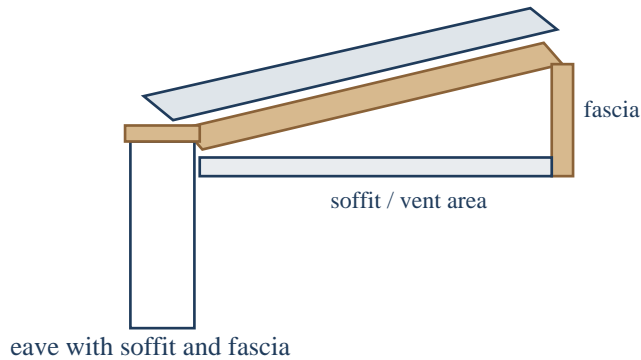

Why edges matter	Things to coordinate early
<ul style="list-style-type: none">• Soffits can supply intake air for a vented roof assembly.• Fascia provides a straight edge for gutters and trim alignment.• Rake details have to meet eave details cleanly at the corners.• Exposed rafter tails need thoughtful weather protection and consistent cutting.	<ul style="list-style-type: none">• Roof sheathing thickness and drip-edge placement.• Vent strip location and insect screening.• Fascia depth versus rafter tail depth.• Whether the roof edge is open, closed, or returns as a cornice.

Field note

Many roofs look crooked because the edge details were left until the end instead of laid out from the start.

7. Dormers, valleys, and framed openings

Dormers make usable space and daylight, but they also create valleys, headers, trimmers, and additional water-management risk. The light-gauge steel example and wood examples both make the same point: openings complicate the roof frame.

Dormers add openings but also create valleys, headers, and extra flashing work.

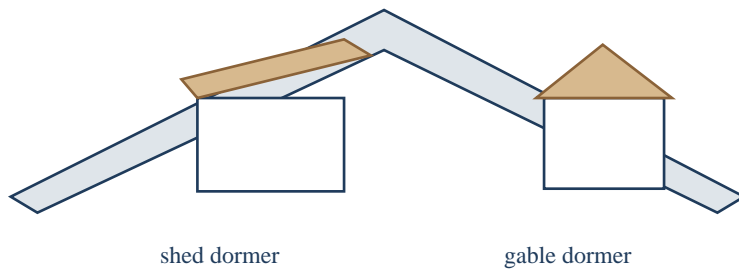

What changes when you add a dormer	Good habits
<ul style="list-style-type: none"> • Common rafters get interrupted and loads must reroute around the opening. • Valley rafters and valley jacks concentrate cuts and water flow. • Headers and trimmers have to be sized and connected correctly. • Flashing complexity rises sharply. 	<ul style="list-style-type: none"> • Lay out the full opening before cutting the surrounding field members. • Keep the dormer small and simple if the project is beginner-level. • Check clear paths for insulation and ventilation around the detail. • Assume valleys deserve extra attention, not less.

Field note

Dormers are where framing skill and waterproofing discipline meet.

8. Flat roofs, roof joists, and parapets

The flat-roof and parapet pages show a system closer to floor framing than to steep rafters. Roof joists need proper bearing, edge support, drainage slope, and careful weather detailing at the perimeter.

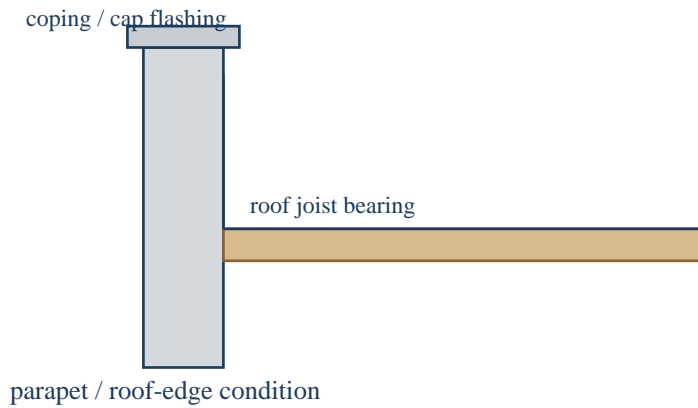

Main ideas	Watch-outs
<ul style="list-style-type: none"> • Flat roofs are rarely truly flat; they still need slope to drain water. • Roof joists need adequate bearing on walls, ledgers, or support lines. • Parapets need coping and flashing details that shed water reliably. • Enclosed roof spaces still need ventilation or another code-compliant moisture-control strategy. 	<ul style="list-style-type: none"> • Flush edge conditions often leak more easily than protected overhang edges. • Parapets can trap water if not flashed and capped well. • Low-slope roofs need disciplined sequencing for membranes and edge metal. • Do not assume a wall detail that works on a steep roof works the same here.

Field note

The easiest flat roof to frame is not always the easiest flat roof to keep dry.

9. Post-and-beam roof framing

Your roof source set includes multiple post-beam connection pages. The big idea is simple: posts carry concentrated loads into beams, and the beam line supports the roof system above. That lets you create open interiors, but the connection details become more important.

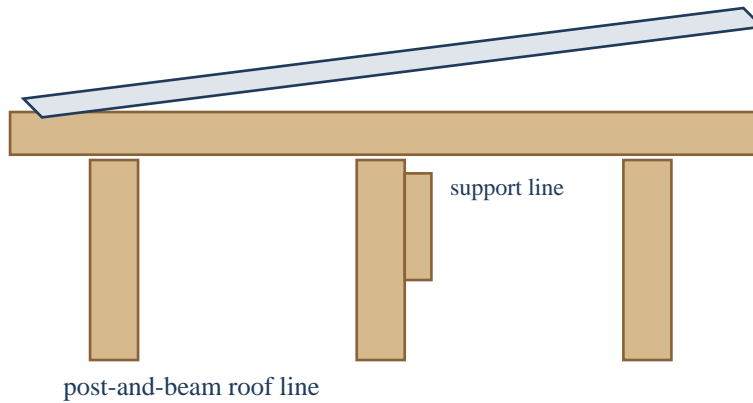

Why builders like it	What demands extra care
<ul style="list-style-type: none"> • Open spans and a strong visual structure. • Clear bearing points that are easy to understand on site. • Potential to leave structure exposed as a finish surface. • Works well with porches, pavilions, and heavy-timber aesthetics. 	<ul style="list-style-type: none"> • Post-to-beam and beam-to-roof connections need real thought, not improvised fasteners. • Lateral bracing still matters even when the vertical gravity path seems obvious. • End grain and exposed tops need weather protection. • Ornamental cuts should never compromise bearing.

Field note

Heavy-looking framing can still fail in a very ordinary way if the connections are weak.

10. Plank-and-beam roof framing

The plank-and-beam pages show another roof family: relatively wide-spaced beams with decking or plank material above. It can create a clean exposed interior, but it offers fewer concealed cavities for services.

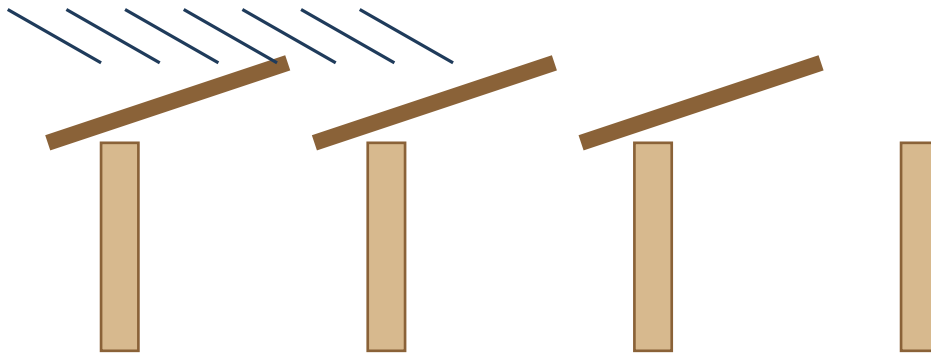

plank-and-beam: wider support spacing with decking above

Where it shines	Limitations
<ul style="list-style-type: none">• Expressive structure with simple primary members.• Decking above beams can act as both structure and interior finish.• Good fit for cabins, pavilions, and strong architectural roof forms.• Secondary framing can be added when spans or geometry demand it.	<ul style="list-style-type: none">• Mechanical and wiring routes are less forgiving than in deep concealed cavities.• Thermal layers often have to be designed above the deck or in a separate build-up.• Connection craftsmanship remains highly visible.• Beam spacing and decking span must be coordinated as one system.

Field note

Plank-and-beam rewards careful detailing because every shortcut stays in view.

11. Roof beams and post-beam connections

The connection sheets in your source set highlight through-bolts, shear plates, straps, gussets, and bearing geometry. The exact hardware varies, but the principle does not: the load must transfer cleanly without crushing, splitting, or letting the frame rack apart.

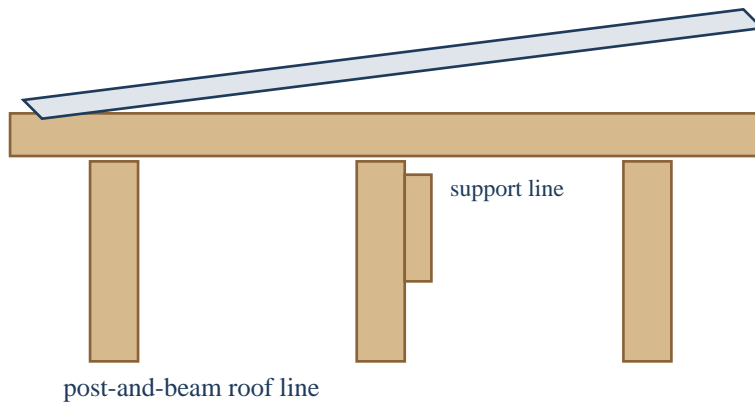

Connection priorities	Bad habits to avoid
<ul style="list-style-type: none"> • Provide full bearing where the beam lands on a post or support. • Use hardware that matches the actual force path: gravity, uplift, or lateral restraint. • Keep bolt patterns realistic for the member size and edge distances. • Do not notch members casually at high-stress zones. 	<ul style="list-style-type: none"> • Stacking too many fasteners into too little wood. • Relying on decorative straps in place of structural connectors. • Leaving bearing surfaces uneven or partially supported. • Exposing vulnerable end grain to weather without protection.

Field note

A connection detail is the place where sketchbook confidence meets real-world force.

12. Light-gauge steel roof framing

The light-gauge steel page mirrors many wood-roof ideas: rafters, joists, ridges, and dormers still exist, but the material behaves differently. Thin steel members rely heavily on proper clips, screws, and manufacturer details.

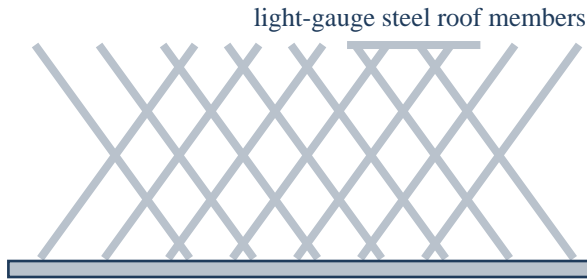

Main reminders	Where people get careless
<ul style="list-style-type: none">• Member spacing still depends on load and sheathing capability.• Anchor clips and compatible fasteners matter; wrong fasteners undermine the system quickly.• Steel members will not tolerate field abuse the same way dimension lumber sometimes does.• Mixed-material interfaces need clear detailing.	<ul style="list-style-type: none">• Assuming a wood habit transfers directly to steel framing.• Cutting or modifying members without checking the manufacturer's system guidance.• Ignoring corrosion issues at exposed or wet locations.• Treating dormer or valley details as simple copy-paste conditions.

Field note

Steel is tidy and efficient, but it punishes sloppy fastening.

13. Moisture control, ventilation, and roof layers

Several source pages repeat the same message in different words: roofs need a plan for water, vapor, and air movement. Structure alone is not enough. The assembly above and below the framing matters.

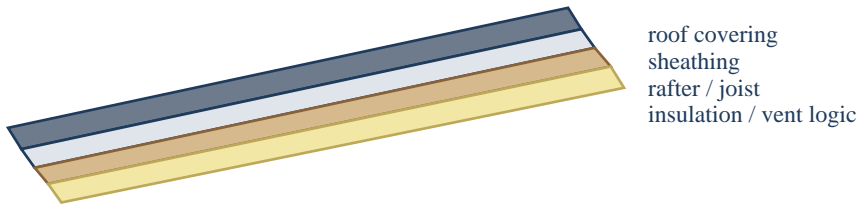

Think in layers	Common failures
<ul style="list-style-type: none">• Roof covering sheds bulk water.• Sheathing ties framing together and supports the covering.• Ventilation or another moisture-control strategy manages condensation risk.• Insulation depth and vent pathways need to coexist.	<ul style="list-style-type: none">• Blocking ventilation paths with insulation.• Creating dead-end air spaces that never actually dry.• Using edge details that trap water at fascia or parapet conditions.• Forgetting that warm moist interior air can become a roof problem.

Field note

Many roof problems begin as moisture problems long before they show up as structural problems.

14. Roof-framing sequencing on site

A lot of jobsite pain comes from bad sequence rather than bad theory. Good layout, repetition, and checking early members save hours later.

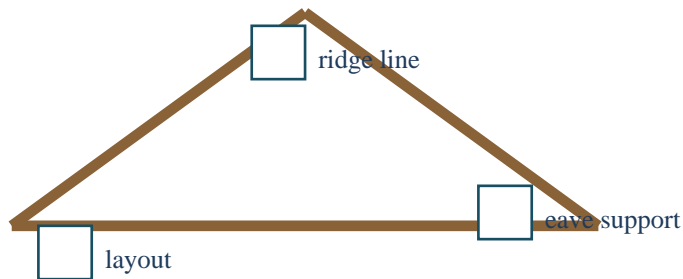

Suggested sequence	Do not rush these
<ul style="list-style-type: none">• Verify wall lines, plate straightness, and support points before lifting members.• Establish the ridge line and first pair of rafters carefully; they control the whole roof.• Check overhangs, tails, and fascia alignment before installing a full field.• Add sheathing in a pattern that helps square and brace the frame.	<ul style="list-style-type: none">• First cuts for the birdsmouth and tail profile.• First valley or dormer layout.• Any change from the repeated common-rafter condition.• Connector installation at uplift-critical points.

Field note

The first two or three members often decide whether the rest of the day is smooth or miserable.

15. Roof-framing field checklist

Use this page as a quick pause-and-check reference before calling the frame complete.

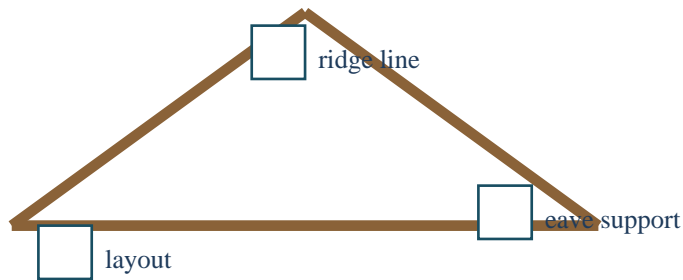

Checklist	Final warning
<ul style="list-style-type: none">• Are bearing points clear, solid, and continuous under all major members?• Are ridge, hip, valley, header, and trimmer conditions framed as intended?• Do the edge details support drainage, ventilation, and trim alignment?• Have all required connectors and uplift restraints actually been installed?• Is the frame straight enough that sheathing and roofing will go on cleanly?• Have you protected vulnerable end grain, exposed cuts, and weather-sensitive details?	<ul style="list-style-type: none">• Stop before covering the roof if something feels improvised. Hidden mistakes become expensive mistakes.

Field note

Roof framing gets judged twice: once on framing day, and again the first time wind and water test it.